



SMRPS341DX-CRB Datasheet

Digital 16bit I2C interface Color + PS

Revision V 1.0
2021-9-18 Updated

Shinawei Technology Co., Ltd.



ENGINEERING CHANGE NOTICE:

Number	Data	Version	Modify	Modify the content
1	2021 - 9 - 18	V 1 . 0	Jason	Create a new specification
2				
3				
4				
5				
6				
7				
8				



Table of Contents

1 Description	4
2 Features	4
3 Applications	4
4 Pin Configuration and Functions	5
5 Specifications	6
6 Detailed Description	10
7 Application	21
8 Package Dimension	22
9 Coding specifications	23



1. Description

The SMRPS341DX-CRB device will perform color temperature, ambient light sensing (ALS) and proximity detection sensing.

An internal state machine provides the ability to put the device into a low power state between proximity and RGBC measurements providing very low average power consumption.

2. Features

- RGB, Ambient Light and IR Sensor
 - Low Power Management
 - I2C Fast Mode Interface Compatible
- Color Temperature and Ambient Light Sensing
 - UV/IR blocking filters
 - Programmable Gain & Integration Time
 - 16 Bit resolution
- Ideal for Operation Behind Dark Glass
 - Very High Sensitivity
- Proximity Detection with an Integrated LED Driver
- Proximity Detection
 - Programmable Offset Control Register
 - Programmable Analog Gain and Integration Time
 - Current Sink Driver for External IR LED
- Power Management
 - Low Power 1uA Sleep State
 - 100uA Wait State with Programmable Wait Time from 3ms to 10seconds
- I2C Interface Compatible
 - Up to 400kHz (I2C Fast Mode)
 - Device address : 7'b0111_001(R/W)

3. Applications

- Ambient Light Sensing
- Color Temperature Sensing
- Cell Phone Touch Screen Disable
- Mechanical Switch Replacement
- Automatic Speakerphone Enable
- Automatic Menu Popup



4. Pin Configuration and Functions

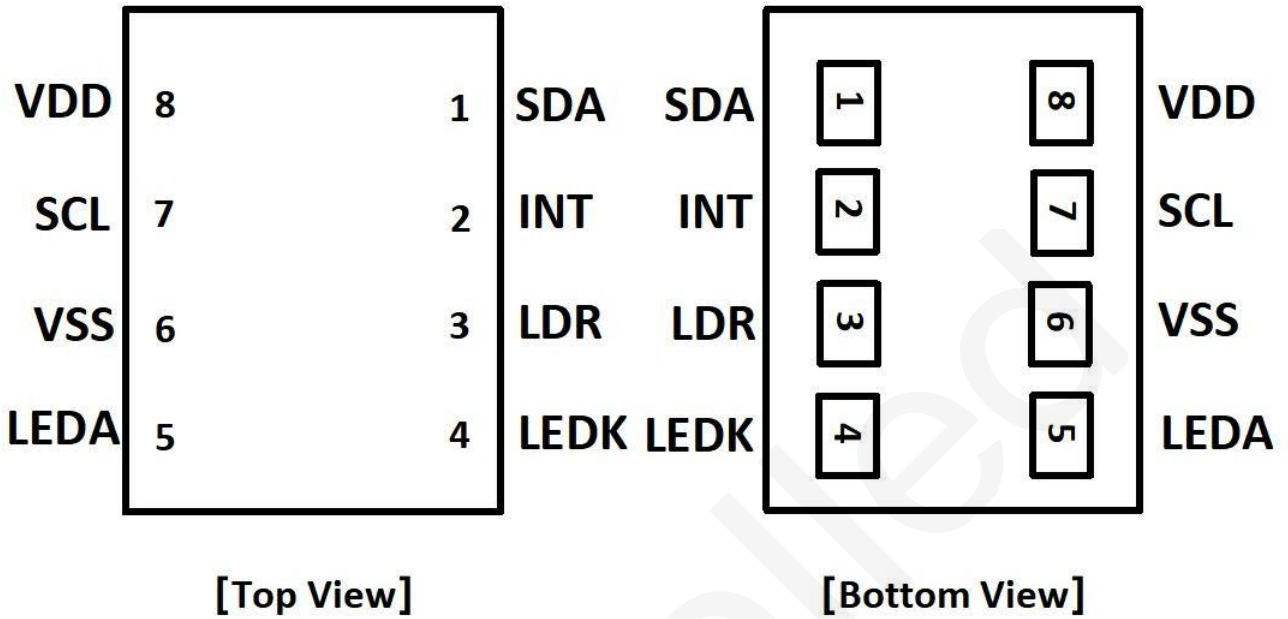

PIN No	PIN Name	TYPE	DESCRIPTION
1	SDA	I/O	I2C serial data input/output terminal
2	INT	O	Interrupt - open drain (active low)
3	LDR	O	Proximity IR LED controlled current sink driver
4	LEDK	O	Vcsel Diode Cathode
5	LEDA	I	Vcsel Diode Anode
6	VSS	G	Supply Ground
7	SCL	I	I2C serial clock input terminal
8	VDD	P	Supply voltage



5. Specifications

5.1 Absolute Maximum Ratings

In Normal RGB mode, Ambient Light Sensor detects ambient light from 0.43lux to 28Klux. The sensitivity of light is 0.43 lux/count, and totally 28Klux in full range; The typical resolution of ADC is 16bits and 5ms conversion time.

In low-lux mode, 10ms of ADC conversion time & 6.9 times of ADC gain is chosen for receiving ambient light. The detect range is 0.03lux to 2060lux.

Considering cover lens with 15% transmittance at 550nm, the ALS detection range is up to 190K lux.

SYMBOL	PARAMETER	MIN	MAX	UNIT
VDD	Power Supply Voltage	-0.5	3.6	V
Vin	Input Voltage	-0.5	VDD	V
Vout	Output Voltage	-0.5	VDD	V
Vhbm	Static Discharge (HBM)		2000	V
Vmm	Static Discharge (MM)		200	V
Tj	Junction Temperature	-40	85	°C

+ Stresses beyond those listed under “absolute maximum ratings” may cause permanent damage to the device. These are stress ratings only and functional operation of the device at these or any other conditions beyond those indicated under “recommended operating conditions” is not implied. Exposure to absolute-maximum-rated conditions for extended periods may affect device reliability.

Note 1: All voltage values are with respect to VSS.

5.2 Recommended Operating Conditions

SYMBOL	PARAMETER	MIN	TYP	MAX	UNIT
VDD	Power Supply Voltage	2.6	3	3.6	V
Vin	Input Voltage	0		VDD	V
Vout	Output Voltage	0		VDD	V
TA	Operating ambient temperature	-20		70	°C



5.3 5.3 Electrical Characteristics (VDD = 3V, Ta = 25°C)

PARAMETER	TEST CONDITIONS	MIN	TYP	MAX	UNIT
Supply Current	Active – LDR pulses off		250	300	uA
	Wait state		100	120	
	Sleep state		1	10	
INT,SDA output low voltage	3mA sink current 6mA sink current	0 0		0.4 0.6	V
Low Level Input Voltage				0.3*VDD	V
High Level Input Voltage		0.7*VDD			V

5.4 Data Transmission Timing Requirements

PARAMETER	CONDITIONS	MIN	MAX	UNIT
Output Low Level (SDA)	IOL = 4mA		0.5	V
SCL Operating Frequency			400	kHz
Stop and Start Condition		1.3		us
Hold Time After Repeated Start Conditions		0.6		us
SCL Clock Low Period		1.3		us
SCL Clock High Period		0.6		us
Repeated Start Condition Setup Time		0.6		us
Data Hold Time		0	0.9	us
Data Setup Time		100		ns
Clock/Data Fall Time			300	ns
Clock/Data Rise Time			300	ns
Stop Condition Setup Time		0.6		us



5.5 5.5 RGBC+IR Characteristics (VDD = 3V, Ta = 25°C, PEN = 1)

PARAMETER		TEST CONDITIONS	MIN	TYP	MAX	UNIT
Peak_Sensitivity Wavelength of ADC	R	-	-	TBD	-	nm
	G	-	-	TBD	-	nm
	B	-	-	TBD	-	nm
	C	-	-	TBD	-	nm
	IR	-	-	TBD	-	nm
Counter Value of ADC	R	Integration Time 0.83ms @ 1300Lux 3000K (In wafer)		TBD		counts
	G			TBD		counts
	B			TBD		counts
	C			TBD		counts
	IR			TBD		counts
Dark Count Value		Dark	0	TBD	TBD	counts
ADC count Range		-	0	-	65535	counts
Gain scaling		GAIN_RGBC = 0 (Low) GAIN_RGBC = 1 (Med) GAIN_RGBC = 2 (High) GAIN_RGBC = 3 (Max)	-	1 1.8 3.1 6.9	-	x



5.6 Proximity Characteristics (VDD = 3V, Ta = 25°C, PEN = 1)

PARAMETER	TEST CONDITIONS		MIN	TYP	MAX	UNIT
Prox. Full count value					65535	counts
LED drive current	PDL = 0	PDRIVE = 0		215		mA
		PDRIVE = 1		182		
PDRIVE = 2			145			
PDRIVE = 3			100			
LED drive current	PDL = 1	PDRIVE = 0		25		mA
		PDRIVE = 1		20		
		PDRIVE = 2		15		
		PDRIVE = 3		10		
Gain scaling	GAIN_PS = 0 (Low) GAIN_PS = 1 (Med) GAIN_PS = 2 (High)			1 1.8 3.1		x

5.7 Typical Performance Characteristics

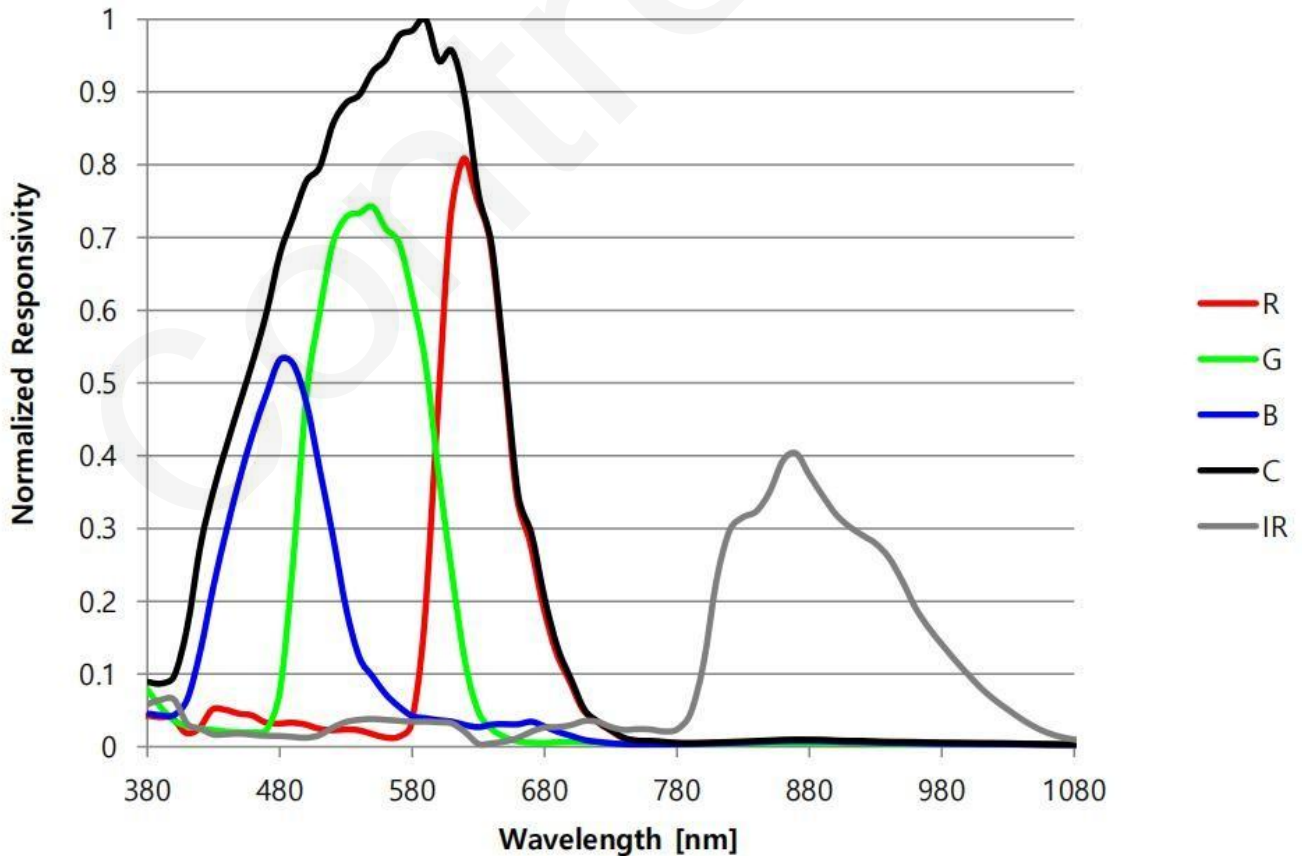



6. Detailed Description

6.1 Overview

The SMRPS341DX-CRB light-to-digital device provides on-chip RGBC and IR diodes, integrating amplifiers, ADCS, accumulators, clocks, buffers, comparators, a state machine and an I2C interface. Four integrating ADCS simultaneously convert the amplified photo diode currents into a digital value providing up to 16 bits of resolution.

The device connects to a video processor or image sensor through a standby I2C interface which supports up to 400-kbits/s data rate. The digital interface supports IO levels from 1.8V to 3.3V.

6.2 Function Block Diagram

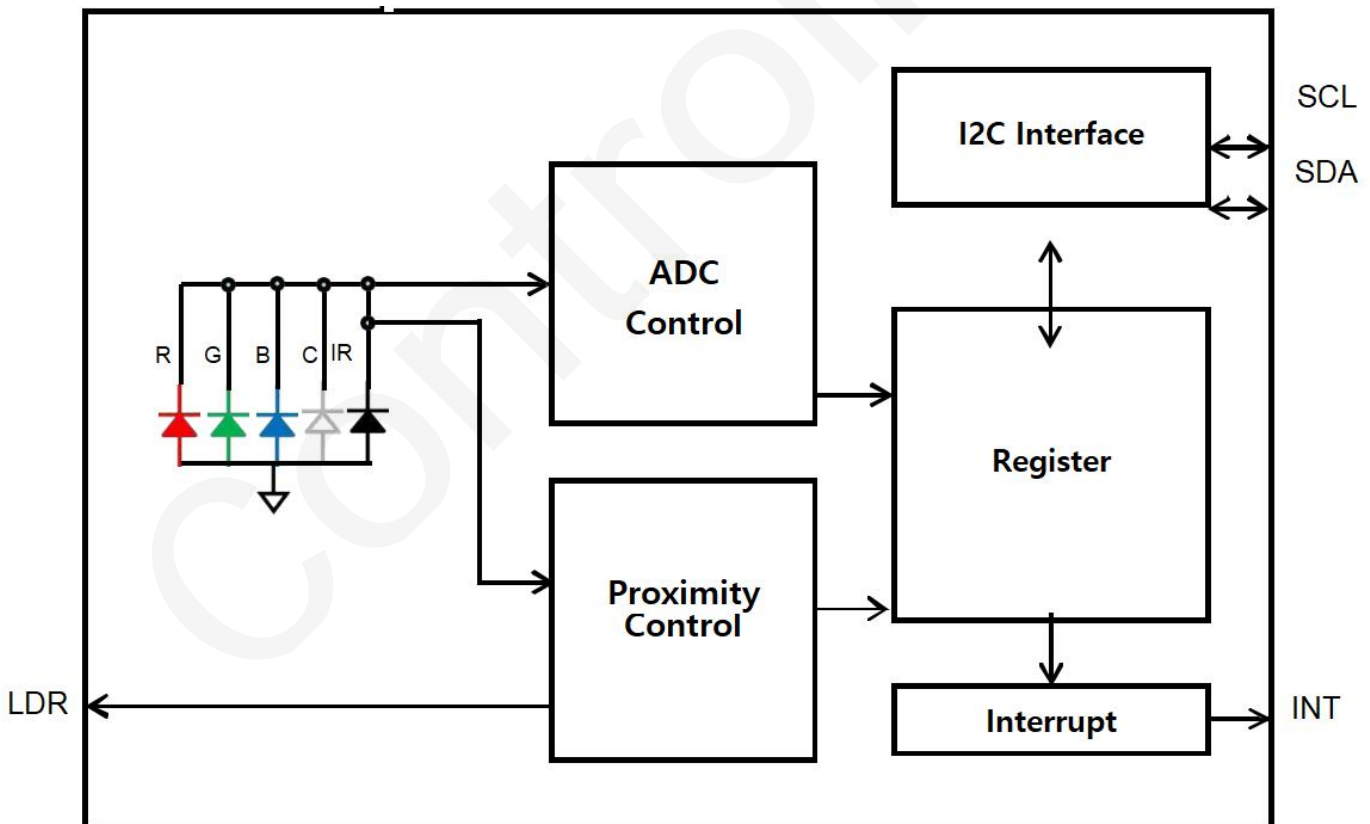



6.3 Feature Description

6.3.1 System State machine

The SMRPS341DX-CRB device provides ambient light, Red, Green, Blue, Clear, IR and Proximity detection sensing. The internal state machine manages the operation of the device. It controls the Color, ALS, PS functionality and power down modes. Average power consumption is managed via control of variable endurance low power wait cycles. The interrupt feature improves system efficiency by eliminating the need to poll the sensor. Two interrupt sources (Clear, PS) can activate the open drain output pin. Each interrupt source is enabled independently. ALS and PS interrupts appear when upper or lower thresholds are exceeded for a consecutive number of sample readings. The advanced digital color light sensor portion of the SMRPS341DX-CRB contains a segmented circular photo diode array used for color measurements. This architecture provides stable color sensing independent of the incident angle of light. Four integrating analog-to-digital converters (ADCS) integrate light energy from photo diodes simultaneously.

Communication with the device is accomplished through a fast (up to 400 kHz) two wire I²C serial bus for easy connection to a micro controller or embedded controller. The device typically draws only 250 μ A in color operation and 1 μ A during power down.

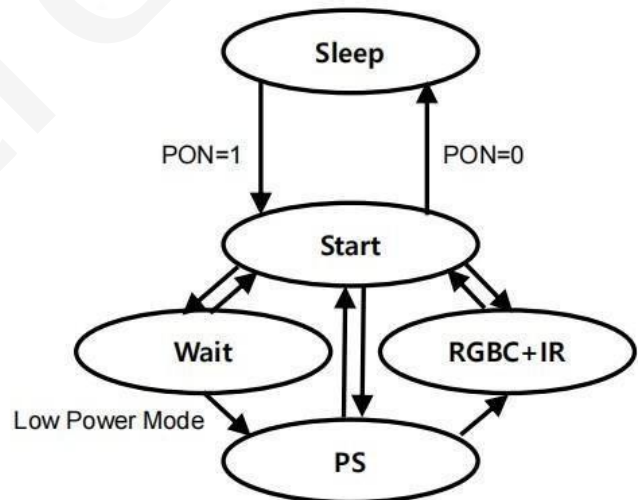

Figure 1. State machine



6.3.2 Proximity Detection

Proximity detection is accomplished by measuring the amount of light energy, generally from an IR LED, reflected off an object to determine its distance. The proximity light source, which is external to the SMRPS341DX-CRB device, is driven by the integrated proximity LED current driver as shown in Figure 2.

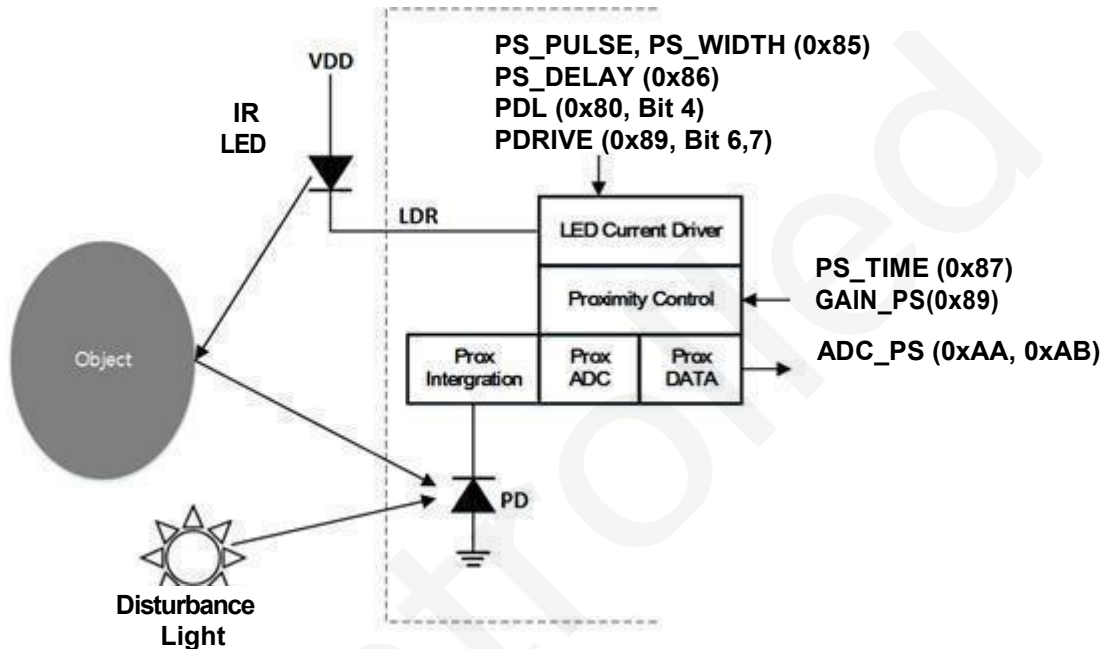

Figure 2. Proximity Detection

The LED current driver, output on the LDR terminal, provides a regulated current sink that eliminates the need for an external current limiting resistor. The combination of proximity LED drive strength (PDRIVE) determine the drive current. PDRIVE sets the drive current to 215mA, 182mA, 145mA, 100mA, 25mA, 20mA, 15mA or 10mA. To drive an external light source with more than 145 mA or to minimize on-chip ground bounce, LDR can be used to drive an external p-type transistor, which in turn drives the light source.



6.3.3 Interrupt

The interrupt feature simplifies and improves system efficiency by eliminating the need to polling the sensor for proximity values outside a user-defined range. While the interrupt function is always enabled and its status is available in the Interrupt register (0x81), the output of the interrupt state can be enabled using the interrupt enable (EI_SEL, EI_PS) field in the Interrupt register (0x81).

Two 16-bit interrupt threshold registers allow the user to set limits below and above a desired proximity range. An interrupt can be generated when the proximity data (PDATA) is less than the proximity interrupt low threshold (INT_LX) or is greater than the proximity interrupt high threshold (INT_HX).

To further control when an interrupt occurs, the device provides an interrupt persistence feature. The persistence filter allows the user to specify the number of consecutive out-of-range proximity occurrences before an interrupt is generated. The persistence filter register (0x8E) allows the user to set the proximity persistence filter (PERS) values. See the persistence filter register for details on the persistence filter values.

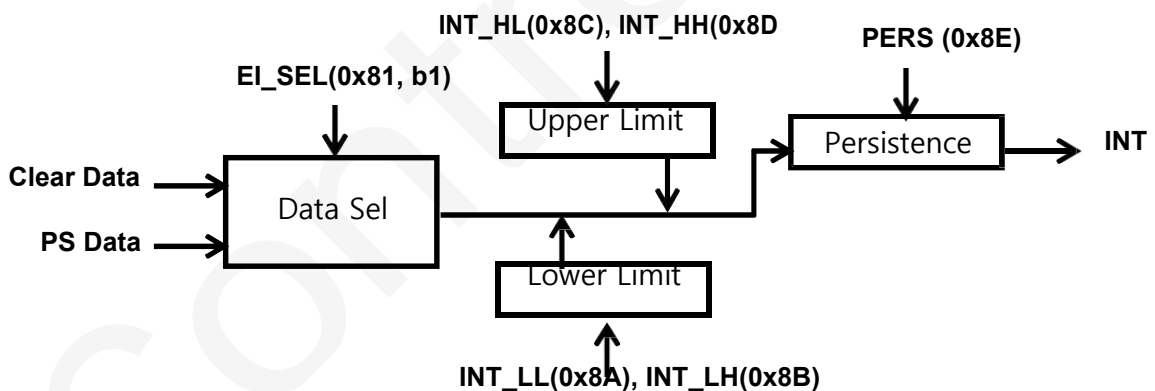

Figure 3. Programmable Interrupt



6.4 Programming

6.4.1 I2C Protocol

Interface and control of the SMRPS341DX-CRB is accomplished through an I2C serial compatible interface (standard or fast mode) to a set of registers that provide access to device control functions and output data. The device supports a single slave address of 7'b0111001 using 7-bit addressing protocol. (Contact factory for other addressing options.)

The I2C standard provides for three types of bus transaction: read, write, and a combined protocol (Figure 4). During a write operation, the first byte written is a command byte followed by data. In a combined protocol, the first byte written is the command byte followed by reading a series of bytes. If a read command is issued, the register address from the previous command will be used for data access. For a complete description of I2C protocols, please review the I2C Specification at: <http://www.semiconductors.philips.com>

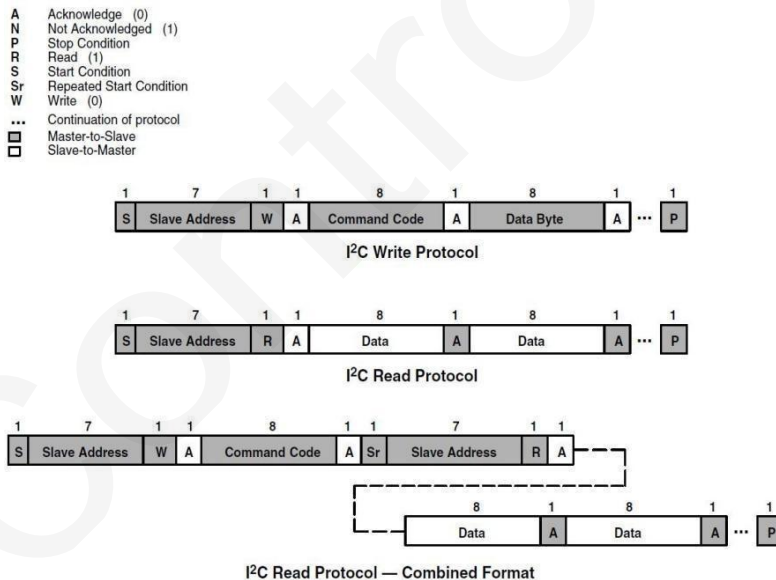

Figure 4. I2C Protocol



6.5 Register Maps

Addr	Bit7	Bit6	Bit5	Bit4	Bit3	Bit2	Bit1	Bit0	DEF
0x80	SAI	INT_TP	PITG	PDL	EN_W	EN_PS	EN_RGB	PON	0x00
0x81			INT_PSH	INT_PSL	INT_V	EI_SEL	EI_PS	EI_VALID	0x00
0x82	50HZ	TIME_BASE			WLONG	TIME_DELAY			0xFF
0x83	TIME_WAIT								0x00
0x84	TIME_RGB								0x00
0x85	PS_PULSE				PS_WIDTH				0x00
0x86	PS_DELAY								0x00
0x87	PS_TIME								0x00
0x88	PS_OFFSET								0x00
0x89	PDRIVE	GAIN_IR			GAIN_PS		GAIN_RGB		0x00
0x8A	INT_LL								0x00
0x8B	INT_LH								0x00
0x8C	INT_HL								0xFF
0x8D	INT_HH								0xFF
0x8E	PERS								0x02
0x98	DEV_ID				REV_ID				0xA0
0xA0	ADC_R[7:0]								0x00
0xA1	ADC_R[15:8]								0x00
0xA2	ADC_G[7:0]								0x00
0xA3	ADC_G[15:8]								0x00
0xA4	ADC_B[7:0]								0x00
0xA5	ADC_B[15:8]								0x00
0xA6	ADC_C[7:0]								0x00
0xA7	ADC_C[15:8]								0x00
0xA8	ADC_IR[7:0]								0x00
0xA9	ADC_IR[15:8]								0x00
0xAA	ADC_PS[7:0]								0x00
0xAB	ADC_PS[15:8]								0x00



6.5.1 Enable Register

Addr	Bit7	Bit6	Bit5	Bit4	Bit3	Bit2	Bit1	Bit0	DEF
0x80	SAI	INT_TP	PITG	PDL	EN_W	EN_PS	EN_RGB	PON	0x00

FIELD	BITS	DESCRIPTION
SAI	7	Sleep After Interrupt. When asserted, the device will power down at the end of a RGB cycle if an interrupt is generated.
INT_TP	6	Interrupt Type. Specify the interrupt retention type. 0: it will be interrupted if it goes out of the threshold, 1; it will occur only when it goes out of the threshold.
PITG	5	PS Integration control. This bit activates the Integration Cap to Double size
PDL	4	LED Current Control of LDR PIN 0: Large current 1: Small current (Large current / 10)
EN_W	3	Wait Timer Enable.
EN_PS	2	Proximity controller Enable.
EN_RGB	1	RGB controller Enable.
PON	0	Power ON. This bit activates the internal oscillator to permit the timers and ADC channels to operate. Writing a 1 activates the oscillator. Writing a 0 disables the oscillator. During reads and writes over the I ² C interface, this bit is temporarily overridden and the oscillator is enabled, independent of the state of PON.



6.5.2 Interrupt control Register

Addr	Bit7	Bit6	Bit5	Bit4	Bit3	Bit2	Bit1	Bit0	DEF
0x81			INT_PSH	INT_PSL	INT_V	EI_SEL	EI_PS	EI_VALI	0x00

FIELD	BITS	DESCRIPTION
INT_PSH	5	1 for interrupts that occur when the PS ADC is above the threshold. Cleared to 0 when reading address 0x81.
INT_PSL	4	1 for interrupts that occur when the PS ADC is below the threshold. Cleared to 0 when reading address 0x81.
INT_V	3	RGB Valid. Indicates that the RGB channels have completed an integration cycle.
EI_SEL	2	Interrupt Data Select 0: PS Data, 1: Clear Data
EI_PS	1	PS interrupt Enable. When asserted permits PS interrupts to be generated,
EI_VALID	0	RGB valid interrupt Enable. When asserted permits RGB valid interrupts to be generated,

6.5.3 Interrupt Persistence Filter Register (0x8E)

The interrupt persistence filter sets the number of consecutive proximity cycles that are out-of-range before an interrupt is generated. Out-of-range is determined by the proximity interrupt threshold registers (0x8A through 0x8D).

Addr	Bit7	Bit6	Bit5	Bit4	Bit3	Bit2	Bit1	Bit0	DEF
0x8E						PERS			0x02

FIELD	BITS	DESCRIPTION
PERS	3:0	Controls rate of interrupt to the host processor 0x1 : 1 proximity value out of range 0x2 : 2 consecutive proximity values out of range 0x3 : 3 consecutive proximity values out of range 0x4 : 5 consecutive proximity values out of range 0x5 : 10 consecutive proximity values out of range ... 0xF : 60 consecutive proximity value out of range



6.5.4 Time control Register

Addr	Bit7	Bit6	Bit5	Bit4	Bit3	Bit2	Bit1	Bit0	DEF
0x82	50HZ	TIME_BASE			WLONG	TIME_DELAY			0xFF
0x83	TIME_WAIT								0x00
0x84	TIME_RGB								0x00
0x85	PS_PULSE				PS_WIDTH				0x00
0x86	PS_DELAY								0x00
0x87	PS_TIME								0x00
0x88	PS_OFFSET								0x00

FIELD	BITS	DESCRIPTION
50HZ	0x82 Bit 7	Set reference time to reduce power noise 0 : 0.83ms (60Hz / 20) 1 : 1ms (50Hz / 20)
TIME_BASE	0x82 Bit 6:4	Set the base time of Wait Timer or RGB ADC. Base Time = Reference Time x (TIME_BASE+1)
WLONG	0x82 Bit 3	Wait Long. When asserted, the wait cycles are increased by a factor 12x from that programmed in the TIME_WAIT register.
TIME_DELAY	0x82 Bit 2:0	Set the delay time to wait to initialize the RGB sensor and ADC. Delay Time = Base Time x (TIME_DELAY+5)
TIME_WAIT	0x83	Set the time of Wait Timer. Wait Time = Base Time x (TIME_WAIT+1)
TIME_RGB	0x84	Set the measurement time of the RGB sensor. Measure Time = Base Time x (TIME_RGB+1)
PS_PULSE	0x85 Bit 7:4	Set Number of LED Pulse. Number of Pluses = PS_PULSE + 1
PS_WIDTH	0x85 Bit 3:0	Set width of LED pulse. Pulse Time = ((PS_WIDTH+1) x 12 x 1.45) x 2 us
PS_DELAY	0x86	Set the delay time before LED pulse drive.
PS_TIME	0x87	Set the PS Discharge Time. PS Discharge time = (PS_TIME + 1) x 128 x 1.45 us
PS_OFFSET	0x88	Set the PS Offset (digital) PS Offset data = PS_OFFSET x 2 (2's compliment)



6.5.5 Gain and Interrupt Threshold Register

Addr	Bit7	Bit6	Bit5	Bit4	Bit3	Bit2	Bit1	Bit0	DEF
0x89	PDRIVE		GAIN_IR		GAIN_PS		GAIN_RGB		0x00
0x8A	INT_LL								0x00
0x8B	INT_LH								0x00
0x8C	INT_HL								0xFF
0x8D	INT_HH								0xFF

FIELD	BITS	DESCRIPTION
PDRIVE	0x89 Bit 7:6	LED Current Level. PDL is 0 : 0: 215mA, 1: 182mA, 2: 145mA, 3: 100mA PDL is 1 : 0: 25mA 1: 20mA, 2: 15mA, 3: 10mA
GAIN_IR	0x89 Bit 5:4	IR Gain 0: x1, 1: x0.5, 2: x0.25, 3: x0.125
GAIN_PS	0x89 Bit 3:2	PS Gain 0: Low, 1: Medium, 2: High
GAIN_RGB	0x89 Bit 1:0	RGB Gain 0: Low, 1: Medium, 2: High, 3: Max
INT_LL	0x8A	Proximity interrupt low threshold low byte
INT_LH	0x8B	Proximity interrupt low threshold high byte
INT_HL	0x8C	Proximity interrupt high threshold low byte
INT_HH	0x8D	Proximity interrupt high threshold high byte



6.5.6 ADC Data

Addr	Bit7	Bit6	Bit5	Bit4	Bit3	Bit2	Bit1	Bit0	DEF
0x98	DEV_ID				REV_ID				0xA0
0xA0					ADC_R[7:0]				0x00
0xA1					ADC_R[15:8]				0x00
0xA2					ADC_G[7:0]				0x00
0xA3					ADC_G[15:8]				0x00
0xA4					ADC_B[7:0]				0x00
0xA5					ADC_B[15:8]				0x00
0xA6					ADC_C[7:0]				0x00
0xA7					ADC_C[15:8]				0x00
0xA8					ADC_IR[7:0]				0x00
0xA9					ADC_IR[15:8]				0x00
0xAA					ADC_PS[7:0]				0x00
0xAB					ADC_PS[15:8]				0x00

FIELD	DESCRIPTION
DEV_ID	Device ID (0xA)
REV_ID	Revision ID (0x0)
ADC_R	RED data
ADC_G	GREEN data
ADC_B	BLUE data
ADC_C	Clear data
ADC_IR	IR data



7 Application

7.1 Typical Application

In a proximity sensing system, the IR LED can be pulsed by the SMRPS341DX-CRB with more than 200 mA of rapidly switching current, therefore, a few design considerations must be kept in mind to get the best performance. The key goal is to reduce the power supply noise coupled back into the device during the LED pulse.

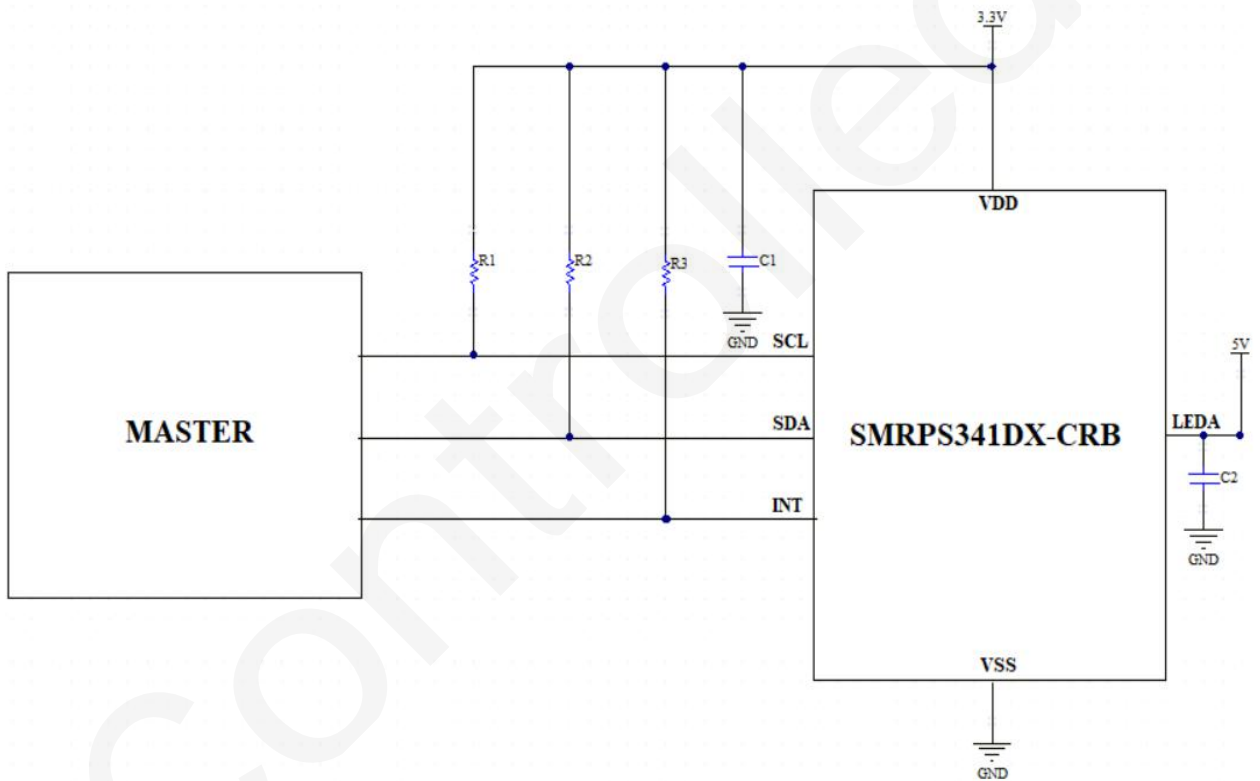



8 Package Dimension

Units [mm]

【Top View】

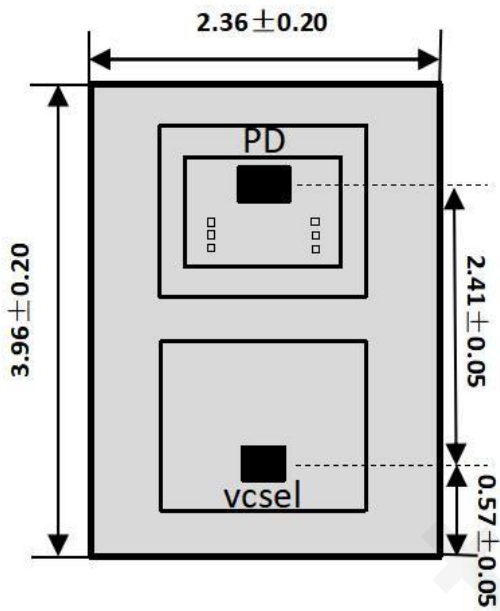

【Side View】

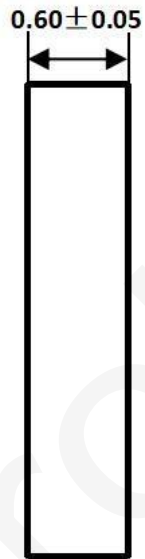

【Bottom View】

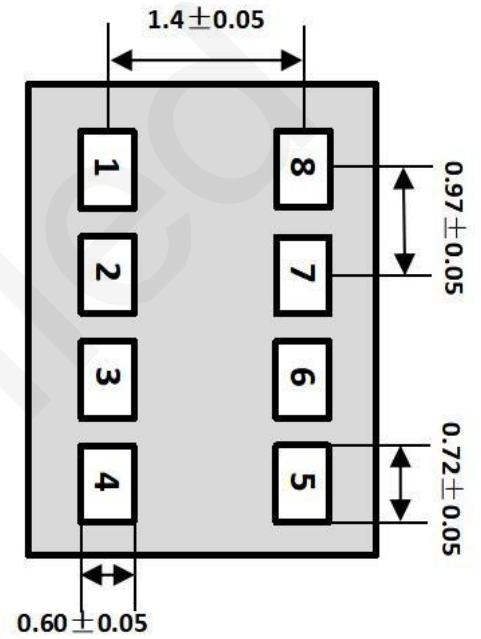



9 Coding specifications

SM XX XXXX X - X X X

① ② ③ ④ ⑤ ⑥ ⑦

① ---- SEMICORE

⑤----- Package:

C : 4.0*2.4*0.65mm OLGA8

② ---- The type of product :
RPS : RGB+PS

⑥ ---- Packaging :
R: Reel

③ ---- P/N

⑦ ---- Apply :
B: Business rules

④----- The type of Light :

VB : 15 mw Vcsel

VC : 210 mw

Vcsel L : IRLED