



SMV9714-DRB Voice Coil Motor Driver

1. Features

- Integrated 10bit DAC for VCM Current Control
- 120mA Current Sink
- Power Down (<1uA)
- Advanced Ringing Compensation for fast settling
- I2C Interface (Fast Mode) : 400KHz, 1.8V~VDD
- Supply voltage range : 2.3V ~ 3.6V
- Operating Temperature Range : -25°C to 80°C
- 6-Ball WLCSP Package With 0.4-mm Pitch
- Size : 0.73mm x 1.13 mm x 0.3mm

2. Application

- Cell Phone Auto Focus
- Digital Still Camera Auto Focus
- Security Cameras
- Web and PC Cameras

3. Description

The SMV9714-DRB is voice coil motor driver for camera auto focus. It has an integrated DAC for setting the VCM current. VCM current is controlled with a linear mode driver.

Current generation can be selected via I2C register. The SMV9714-DRB device has an integrated sense resistor for current regulation and the current can be controlled through I2C. The I2C address for the SMV9714-DRB is 0x18.

When changing the current in the VCM, the lens ringing is compensated with an advanced ringing compensation function. Ringing compensation reduces the needed time for auto focus significantly.

Simplified Schematic

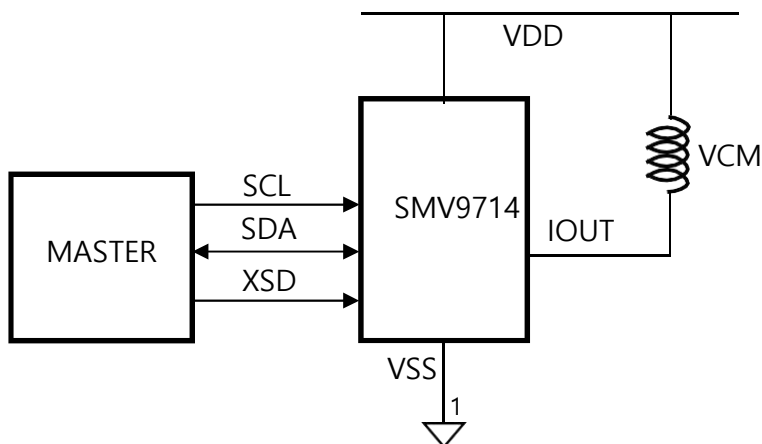

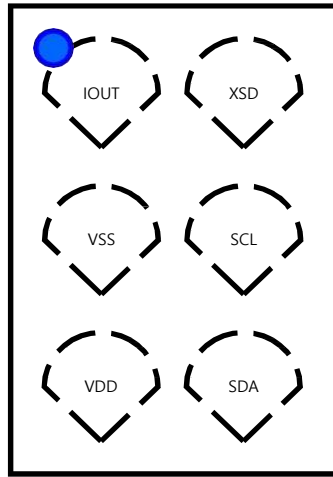

Table of Contents

1 Features	1	7 Application	15
2 Application	1	8 PKG Dimension	16
3 Description	1		
4 Pin Configuration and Functions	3		
5 Specifications	4		
6 Detailed Description	7		



4. Pin Configuration and Functions



Top View

Pin Functions

PIN	I/O/P	DESCRIPTION
IOUT	O	Voice coil output current sink
VSS	P	Supply Ground
VDD	P	Supply Power
SDA	I/O	I2C data input/output
SCL	I	I2C clock input
XSD	I	Shutdown (active low)



5. Specifications

5.1 Absolute Maximum Ratings

SYMBOL	PARAMETER	MIN	MAX	UNIT
VDD	Power Supply Voltage	-0.5	5.5	V
V _{in}	Input Voltage	-0.5	VDD+0.5	V
V _{out}	Output Voltage	-0.5	VDD+0.5	V
V _{HBM}	Static Discharge (HBM)		2	kV
V _{MM}	Static Discharge (MM)		200	V
T _j	Junction Temperature	-40	85	°C

+ Stresses beyond those listed under "absolute maximum ratings" may cause permanent damage to the device. These are stress ratings only and functional operation of the device at these or any other conditions beyond those indicated under "recommended operating conditions" is not implied. Exposure to absolute-maximum-rated conditions for extended periods may affect device reliability.

Note 1: All voltage values are with respect to VSS.

5.2 Recommended Operating Conditions

SYMBOL	PARAMETER	MIN	TYP	MAX	UNIT
VDD	Power Supply Voltage	2.3	2.8	3.6	V
V _{in}	Input Voltage	0		VDD	V
V _{out}	Output Voltage	0		VDD	V
TA	Operating ambient temperature	-25		80	°C



5.3 Electrical Characteristics(VDD = 2.8V, Ta=25°C)

PARAMETER	TEST CONDITIONS	MIN	TYP	MAX	UNIT
Supply Current	Shutdown mode	-1		+1	uA
	Active mode		0.35	0.45	mA
Low Level Input Voltage				0.3VDD	V
High Level Input Voltage		0.7VDD			V
Output Resolution			10		bits
DNL		-1	0	1	LSB
INL		-10	0	10	LSB
Maximum output current		114	120	126	mA
Zero Code error		1	0	1	mA
Internal voltage dropout	100mA		0.18	0.25	V



5.4 Data Transmission Timing Requirements

PARAMETER	Symbol	CONDITIONS	MIN	MAX	UNIT
Output Low Level (SDA)	V_{OL}	IOL = 4mA		0.5	V
SCLK Operating Frequency	f_{SCLK}			400	kHz
Stop and Start Condition	t_{BUF}		1.3		us
Hold Time After Repeated Start Conditions	$t_{HD;STA}$		0.6		us
SCLK Clock Low Period	t_{LOW}		1.3		us
SCLK Clock High Period	t_{HIGH}		0.6		us
Repeated Start Condition Setup Time	$t_{SU;STA}$		0.6		us
Data Hold Time	$t_{HD;DAT}$		0	0.9	us
Data Setup Time	$t_{SU;DAT}$		100		ns
Clock/Data Fall Time	t_F			300	ns
Clock/Data Rise Time	t_R			300	ns
Stop Condition Setup Time	$t_{SU;STO}$		0.6		us

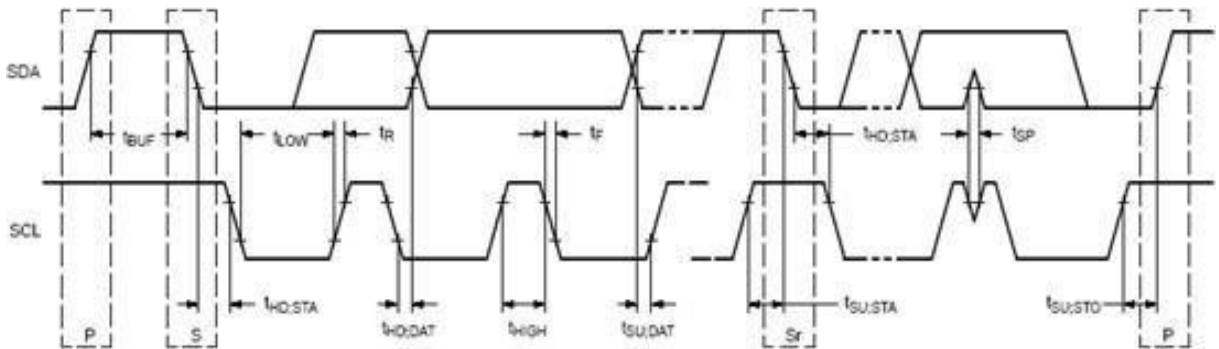



6. Detailed Description

6.1 Overview

The SMV9714-DRB is intended for high performance autofocus in camera modules. The device is used to control the current in the voice coil motor (VCM). The VCM current and thus the lens position can be controlled via the I2C interface and an auto focus function can be implemented.

The device connects to a video processor or image sensor through a standby I2C interface which supports up to 400-kbits/s data rate. The digital interface supports IO levels from 1.8V to 3.3V.

6.2 Function Block Diagram

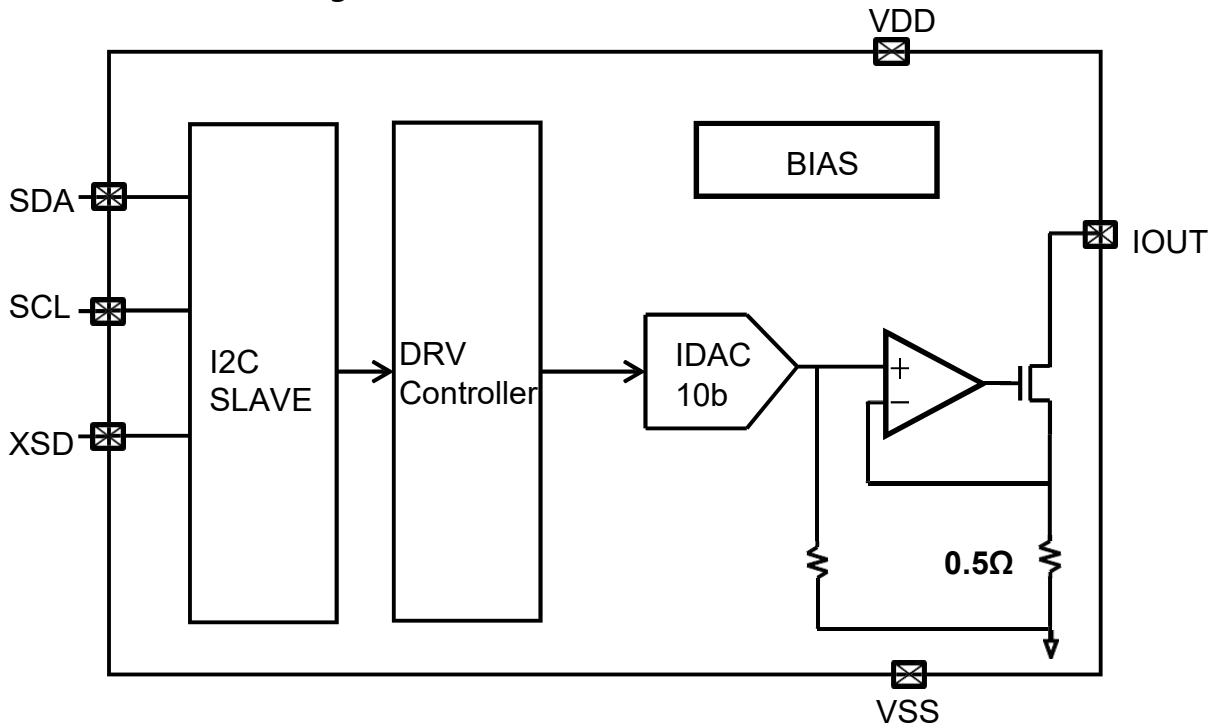



6.3 Feature Description

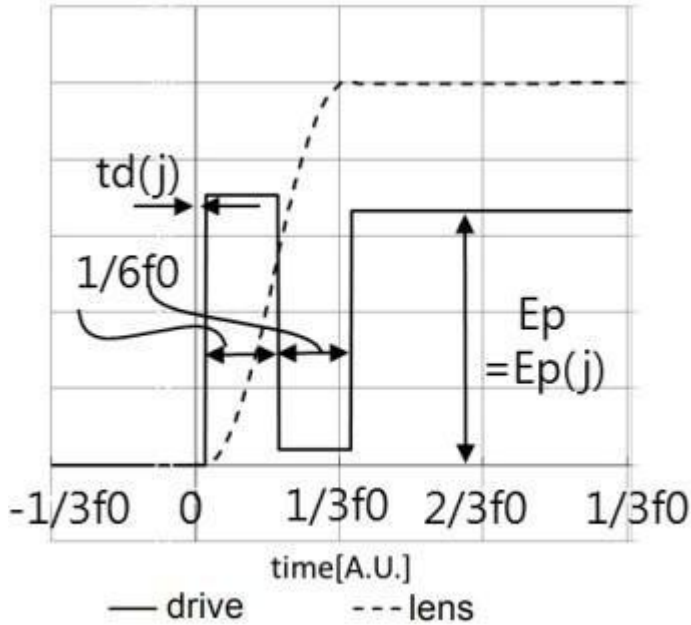

6.3.1 Ringing Compensation

VCM current can be controlled via a I2C interface and OUT_CURRENT register.

Lens stack is connected to a spring which caused a dampened ringing in the lens position when current is changed. This mechanical ringing is compensated internally by generating an optimized ramp whenever the current value is the OUT_CURRENT register is changed. This enables a fast auto focus algorithm and user experience.

The SMV9714-DRB has setting drive delay time, energy lost by friction, resonance frequency for ringing compensation.

ADDRESS	NAME	FUNCTION	R/W
07h ~ 08h	TD0	drive delay time ($TD0 * 10\mu s$)	R/W
09h ~ 0Ah	TD1	drive delay time ($TD1 * 10\mu s$)	R/W
13h ~ 14h	F0	resonance frequency	R/W
15h ~ 16h	EF	energy loosed by friction	R/W



6.4 Device Functional Modes

6.4.1 Mode of Operation

Shutdown If the device will enter shutdown mode when XSD pin is low or power down register is high. default is Active mode.

Active The device is in Active mode when power on. In Active mode VCM driver output is enabled all the time resulting in higher power consumption.

6.5 Programming

6.5.1 I2C Bus Operation

The SMV9714-DRB hosts a slave I2C interface that supports data rates up to 400- kbits/s and auto-increment addressing and is compliant to I2C standard 3.0.

Register Write

A register is written by first sending the command byte, with the device address and read/write set to "L"(write). Then a register address byte is sent, which selects which register is to be written (RA7-RA0 below).

Finally, the data byte is sent, which is latched into the addressed register when complete.

Note that additional writes may be performed without sending a stop; in this case the register address will automatically increment and the following 8-bit register will be written.

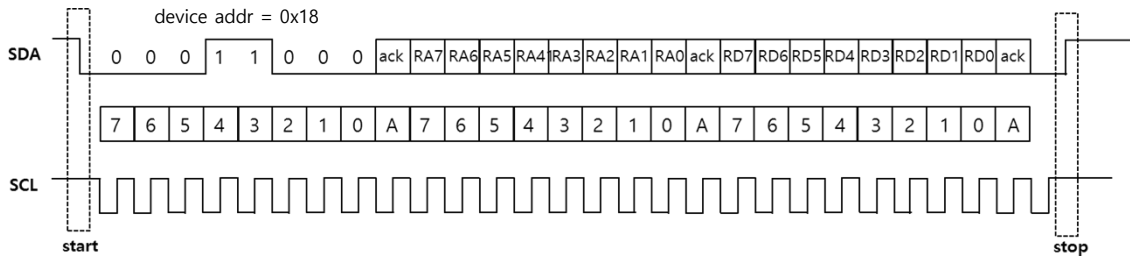

Register Read

A register is read by first sending the command byte, with the device address and read/write set to "0"(write).

Then a register address byte is sent (RA7-RA0 below), which selects which register is to be read.

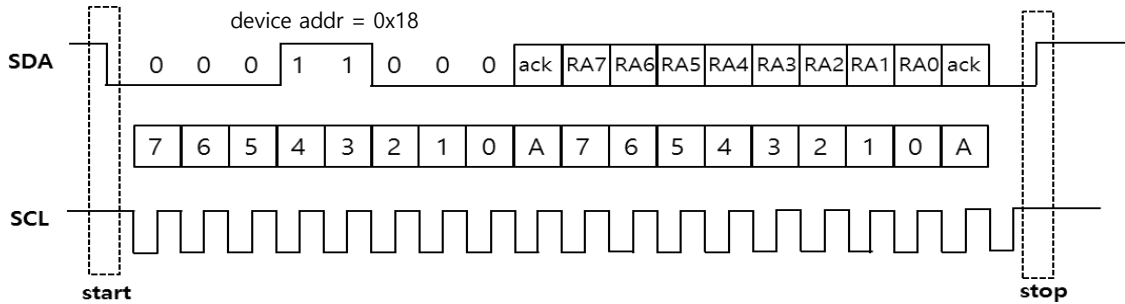

Following the register selection, another command byte is sent, again addressing the device, but with the read/write bit set to "1" (read). Then the data from the addressed register is read.

Note that additional reads may be performed without sending a stop; in this case the register address will automatically increment and the following 8-bit register will be read.

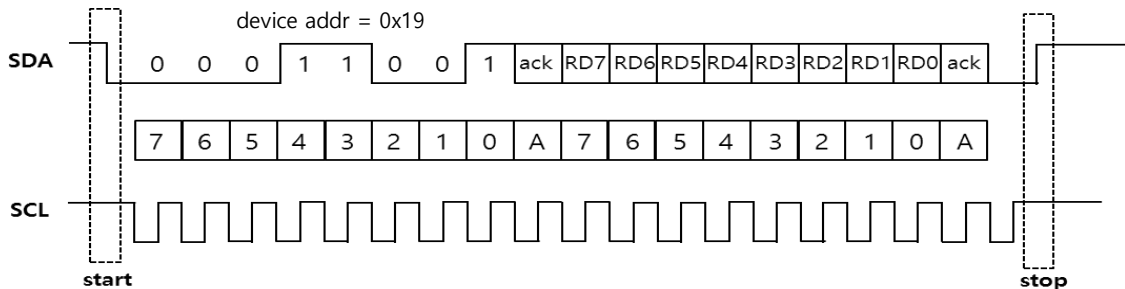



6.5.2 DIG_FIL (Address – 0x00h)

Digital Filter ON/OFF (default off)

* When The IC is powered on, Digital filter must be turned on.

DATA BIT	D7	D6	D5	D4	D3	D2	D1	D0
0x00h	not used	not used	not used	not used	not used	not used	not used	DIG_FIL

6.6.1 OUT_CURRENT (Address – 0x02h,0x3h)

Output current = (OUT_CURRENT[9:0]/1023) / 120mA

DATA BIT	D7	D6	D5	D4	D3	D2	D1	D0
0x02h	not used	not used	OUT_CURRENT[9:4]					
0x03h	OUT_CURRENT[3:0]				not used	not used	not used	not used

6.6.2 ENABLE (Address – 0x04h)

Target Controller Enable, Shape Controller Enable

DATA BIT	D7	D6	D5	D4	D3	D2	D1	D0
0x04h	not used	not used	not used	not used	not used	not used	Target Controller Enable	Shape Controller Enable

6.6.3 TD0 (Address – 0x07h,0x08h)

Controller0 output delay time (= TD0 * 10us)

DATA BIT	D7	D6	D5	D4	D3	D2	D1	D0
0x07h	not used	not used	not used	not used	TD0[11:8]			
0x08h	TD0[7:0]							



6.6.4 TD1 (Address – 0x09h,0x0Ah)

Controller1 output delay time (= TD1 * 10us)

DATA BIT	D7	D6	D5	D4	D3	D2	D1	D0
0x09h	not used	not used	not used	not used	TD1[11:8]			
0x0Ah	TD1[7:0]							

6.6.5 TD2 (Address – 0x0Bh,0x0Ch)

Shape Controller output delay time (= TD2 * 10us)

DATA BIT	D7	D6	D5	D4	D3	D2	D1	D0
0x0Bh	not used	not used	not used	not used	TD2[11:8]			
0x0Ch	TD2[7:0]							

6.6.6 NJ (Address – 0x0Dh)

NJ ON / OFF (high is ON)

DATA BIT	D7	D6	D5	D4	D3	D2	D1	D0
0x0Dh	not used	not used	not used	not used	not used	not used	not used	NJ

NJ is setting register for driving ofattenuation.

0 : driving of attenuation off

1 : driving of attenuation on



6.6.7 Height (Address – 0x0Fh,0x10h)

Shape Controller output amplitude.

$$\text{amplitude} = \text{output current} * (\text{Height} / 255)$$

DATA BIT	D7	D6	D5	D4	D3	D2	D1	D0
0x0Fh	not used	not used	not used	not used	not used	not used	Height[9:8]	
0x10h	Height[7:0]							

6.6.8 Width (Address – 0x11h,0x12h)

Shape Controller output time (= Width * 10us)

DATA BIT	D7	D6	D5	D4	D3	D2	D1	D0
0x11h	not used	not used	not used	not used	Width[11:8]			
0x12h	Width[7:0]							

6.6.9 F0 (Address – 0x13h,0x14h)

F0 is Resonance Frequency

DATA BIT	D7	D6	D5	D4	D3	D2	D1	D0
0x13h	not used	not used	not used	not used	not used	not used	F0[9:8]	
0x14h	F0[7:0]							

6.6.10 EF (Address – 0x15h,0x16h)

EF is energy lost by friction

$$\text{energy lost by friction}(\%) = (\text{EF} / 512) * 100$$

DATA BIT	D7	D6	D5	D4	D3	D2	D1	D0
0x15h	not used	not used	not used	not used	EF[11:8]			
0x16h	EF[7:0]							



7. Application

7.1 Typical Application

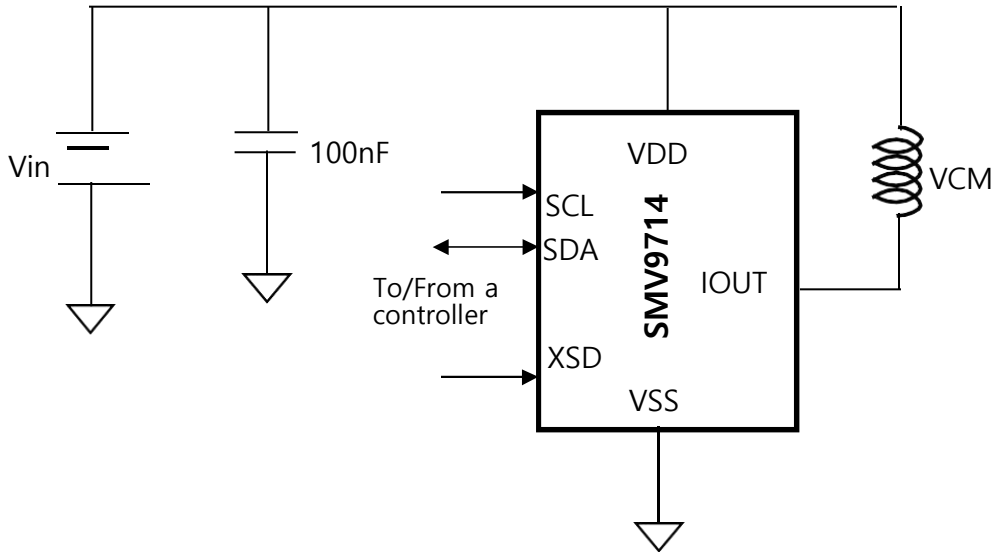

7.2 Application Curve

Settling time is 7.0ms for step size 100um(19.2mA = 240code) interval 40ms (10% error band)





8. PKG Dimension

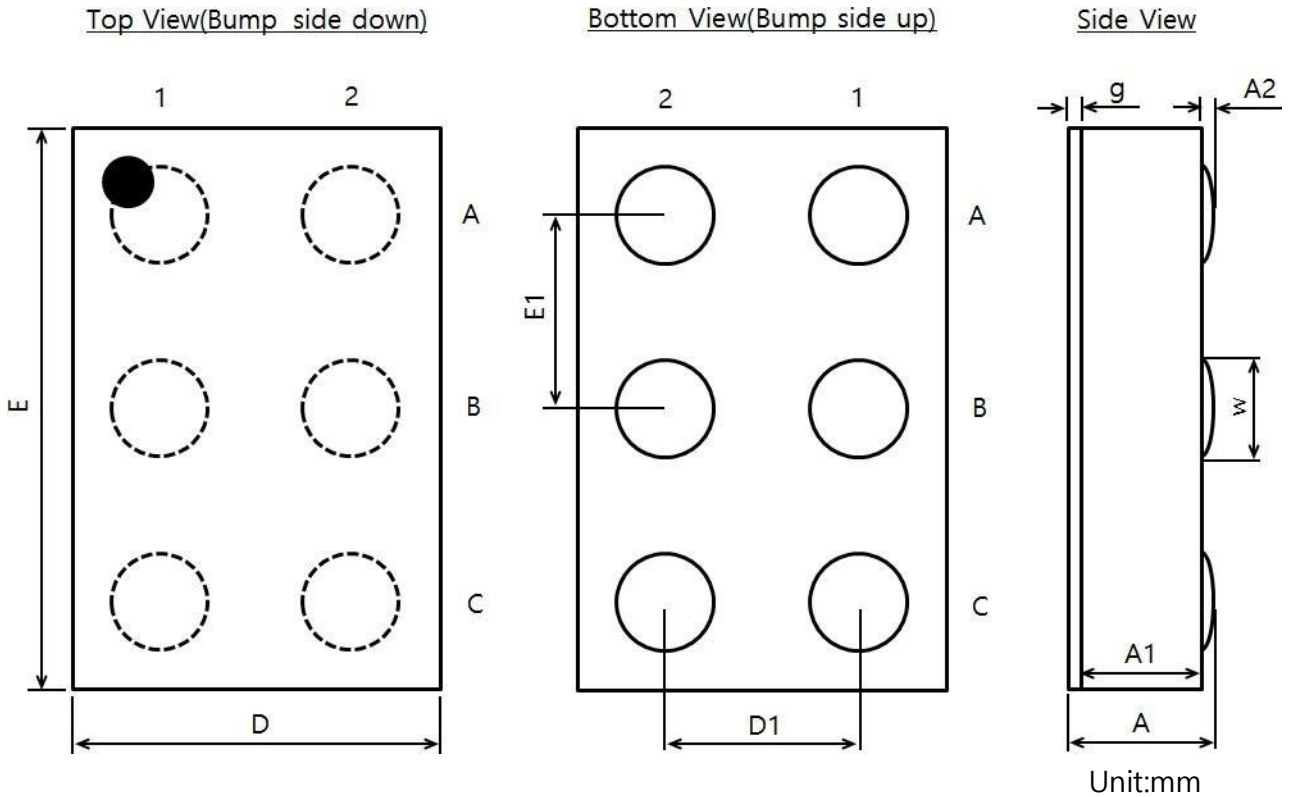

DIMENSION

Symbols	MIN	NOM	MAX	Note
A	0.262	0.300	0.338	±0.038
A1	0.230	0.250	0.270	±0.020
A2	0.010	0.025	0.040	±0.015
D	0.700	0.730	0.760	±0.030
E	1.100	1.130	1.160	±0.030
D1	0.400			
E1	0.400			
g	0.022	0.025	0.028	±0.003
w	0.170	0.200	0.230	±0.030